**Measurement of water flow in fully
charged closed conduits — Meters for
cold potable water and hot water —**

**Part 1:
Specifications**

*Mesurage de débit d'eau dans les conduites fermées en pleine
charge — Compteurs d'eau potable froide et d'eau chaude —*

Partie 1: Spécifications



Reference number
ISO 4064-1:2005(E)

© ISO 2005

PDF disclaimer

This PDF file may contain embedded typefaces. In accordance with Adobe's licensing policy, this file may be printed or viewed but shall not be edited unless the typefaces which are embedded are licensed to and installed on the computer performing the editing. In downloading this file, parties accept therein the responsibility of not infringing Adobe's licensing policy. The ISO Central Secretariat accepts no liability in this area.

Adobe is a trademark of Adobe Systems Incorporated.

Details of the software products used to create this PDF file can be found in the General Info relative to the file; the PDF-creation parameters were optimized for printing. Every care has been taken to ensure that the file is suitable for use by ISO member bodies. In the unlikely event that a problem relating to it is found, please inform the Central Secretariat at the address given below.

© ISO 2005

All rights reserved. Unless otherwise specified, no part of this publication may be reproduced or utilized in any form or by any means, electronic or mechanical, including photocopying and microfilm, without permission in writing from either ISO at the address below or ISO's member body in the country of the requester.

ISO copyright office
Case postale 56 • CH-1211 Geneva 20
Tel. + 41 22 749 01 11
Fax + 41 22 749 09 47
E-mail copyright@iso.org
Web www.iso.org

Published in Switzerland

Contents

Page

Foreword.....	iv
1 Scope	1
2 Normative references	1
3 Terms and definitions.....	2
4 Technical characteristics	8
4.1 In-line meters.....	8
4.2 Concentric meters	10
4.3 Pressure loss	11
5 Metrological requirements	12
5.1 Metrological characteristics	12
5.2 Maximum permissible error.....	13
5.3 Zero flow totalization	14
5.4 Rated operating conditions (ROC).....	14
5.5 Flow profile sensitivity classes	16
5.6 Requirements for electronic meters and meters with electronic devices	17
6 Technical requirements	19
6.1 Requirements for materials and construction of water meters	19
6.2 Endurance	19
6.3 Adjustment of water meters	19
6.4 Verification marks and protection devices	19
6.5 Electronic sealing devices	19
6.6 Indicating device.....	20
6.7 Water meters equipped with electronic devices	23
6.8 Descriptive markings.....	30
Annex A (informative) Concentric water meter manifold	32
Annex B (informative) Design features and actual flowrates of water meters.....	35
Annex C (normative) Checking facilities	37
Bibliography	41

Foreword

ISO (the International Organization for Standardization) is a worldwide federation of national standards bodies (ISO member bodies). The work of preparing International Standards is normally carried out through ISO technical committees. Each member body interested in a subject for which a technical committee has been established has the right to be represented on that committee. International organizations, governmental and non-governmental, in liaison with ISO, also take part in the work. ISO collaborates closely with the International Electrotechnical Commission (IEC) on all matters of electrotechnical standardization.

International Standards are drafted in accordance with the rules given in the ISO/IEC Directives, Part 2.

The main task of technical committees is to prepare International Standards. Draft International Standards adopted by the technical committees are circulated to the member bodies for voting. Publication as an International Standard requires approval by at least 75 % of the member bodies casting a vote.

Attention is drawn to the possibility that some of the elements of this document may be the subject of patent rights. ISO shall not be held responsible for identifying any or all such patent rights.

ISO 4064-1 was prepared by Technical Committee ISO/TC 30, *Measurement of fluid flow in closed conduits*, Subcommittee SC 7, *Volume methods including water meters*.

This third edition cancels and replaces the second edition (ISO 4064-1:1993), which has been technically revised as well as cancelling and replacing ISO 7858-1:1998 and ISO 10385-1:2000.

ISO 4064 consists of the following parts, under the general title *Measurement of water flow in fully charged closed conduits — Meters for cold potable water and hot water*.

- *Part 1: Specifications*
- *Part 2: Installation requirements*
- *Part 3: Test methods and equipment*

Measurement of water flow in fully charged closed conduits — Meters for cold potable water and hot water —

Part 1: Specifications

1 Scope

This part of ISO 4064 specifies terminology, technical characteristics, metrological characteristics and pressure loss requirements for cold potable water and hot water meters. It applies to water meters that can withstand maximum admissible working pressures (MAP) $\geq 1 \text{ MPa}^{1)}$ (0,6 MPa for meters for use with pipe nominal diameters, DN $\geq 500 \text{ mm}$) and a maximum admissible temperature, MAT, for cold potable water meters of 30 °C and for hot water meters up to 180 °C, depending on class.

This part of ISO 4064 also applies to water meters, based on electrical or electronic principles and to water meters based on mechanical principles incorporating electronic devices, used to meter the actual volume flow of cold potable water and hot water. It also applies to electronic ancillary devices. Generally ancillary devices are optional.

The specifications of this part of ISO 4064 apply to water meters, irrespective of technology, defined as integrating measuring instruments continuously determining the volume of water flowing through them.

NOTE National regulations may apply in the country of use. These will take precedence over the provisions of this part of ISO 4064.

2 Normative references

The following referenced documents are indispensable for the application of this document. For dated references, only the edition cited applies. For undated references, the latest edition of the referenced document (including any amendments) applies.

ISO 3:1973, *Preferred numbers — Series of preferred numbers*

ISO 228-1, *Pipe threads where pressure-tight joints are not made on the threads — Part 1: Dimensions, tolerances and designation*

ISO 4064-3:2005, *Measurement of water flow in fully charged closed conduits — Meters for cold potable water and hot water — Part 3: Test methods and equipment*

ISO 6817 *Measurement of conductive liquid flow in closed conduits — Method using electromagnetic flowmeters*

ISO 7005-2, *Metallic flanges — Part 2: Cast iron flanges*

1) 0,1 MPa = 1 bar

ISO 7005-3, *Metallic flanges — Part 3: Copper alloy and composite flanges*

OIML D 11:1994, *General requirements for electronic measuring instruments*

OIML V 1:2000, *International vocabulary of terms in legal metrology (VIML)*

OIML V 2: 1993, *International vocabulary of basic and general terms in metrology (VIM)*

3 Terms and definitions

For the purposes of this document, the terms and definitions given in OIML V 2 and OIML V 1 and the following apply.

NOTE The terms 3.27 to 3.43 are typically associated with electronic and electrical equipment.

3.1 flowrate

Q
quotient of the actual volume of water passing through the water meter and the time taken for this volume to pass through the water meter

3.2 actual volume

V_a
total volume of water passing through the water meter, disregarding the time taken

NOTE This is the measurand of the meter.

3.3 indicated volume

V_i
volume of water indicated by the meter, corresponding to the actual volume

3.4 maximum permissible error MPE

extreme values of the relative error of indication of the water meter permitted by this part of ISO 4064

3.5 rated operating conditions ROC

conditions of use giving the range of values of the influence factors, for which the errors of indication of the water meter are required to be within the MPE

3.6 limiting conditions LC

extreme conditions, including flowrate, temperature, pressure, humidity and electromagnetic interference, EMI, that a water meter is required to withstand without damage, and without degradation of its error of indication, when it is subsequently operated within its ROC

NOTE 1 The above refers to both upper and lower LC.

NOTE 2 The LC for storage, transport and operation may be different.

3.7 relative error

error of indication divided by the actual volume, expressed as a percentage

3.8**error of indication**

indicated volume minus the actual volume

3.9**permanent flowrate**
 Q_3

highest flowrate within ROC at which a water meter is required to operate in a satisfactory manner within the maximum permissible error

3.10**overload flowrate**
 Q_4

highest flowrate at which a water meter is required to operate for a short period of time within its MPE, whilst maintaining its metrological performance when it is subsequently operated within its ROC

3.11**minimum flowrate**
 Q_1

lowest flowrate at which the water meter is required to operate within the MPE

3.12**transitional flowrate**
 Q_2

flowrate which occurs between the permanent flowrate, Q_3 , and minimum flowrate, Q_1 , that divides the flowrate range into two zones, the “upper zone” and the “lower zone”, each characterized by its own MPE

3.13**minimum admissible working temperature**
mAT

minimum temperature that a water meter can withstand permanently at a given internal pressure, without deterioration of its metrological performance

3.14**maximum admissible working temperature**
MAT

maximum temperature that a water meter can withstand permanently at a given internal pressure, without deterioration of its metrological performance

NOTE mAT and MAT are respectively the lower and upper limits of the ROC for working temperature.

3.15**minimum admissible working pressure**
mAP

minimum pressure that a water meter can withstand permanently within ROC, without deterioration of its metrological performance

3.16**maximum admissible working pressure**
MAP

maximum pressure that a water meter can withstand permanently within ROC, without deterioration of its metrological performance

NOTE mAP and MAP are respectively the lower and upper limits of the ROC for working pressure.

3.17**working temperature**
 T_w

average water temperature in the pipe, measured upstream and downstream of the water meter

3.18
working pressure

P_w

average water pressure in the pipe, measured upstream and downstream of the water meter

3.19
pressure loss

Δp

head loss, at a given flowrate caused by the presence of the meter in the pipeline

3.20
in-line meter

type of water meter, fitted directly into a closed conduit by means of the meter end connections (threaded or flanged) provided

3.21
combination meter

in-line type of water meter comprising one large flowrate meter, one small flowrate meter and a changeover device that, depending on the magnitude of the flowrate passing through the meter, automatically directs the flow through either the small or large meter or both

NOTE The meter reading is obtained from two independent totalizers or one totalizer, which adds up the values from both water meters.

3.22
concentric meter

type of water meter fitted into a closed conduit by means of an intermediate fitting called a manifold, whereby the inlet and outlet passages of the meter and manifold, at the interface between them, are coaxial

3.23
concentric meter manifold

pipefitting specific to the connection of a concentric meter

3.24
complete meter

meter that does not have separable measurement transducer (including flow sensor) and calculator (including indicating device)

3.25
combined meter

meter that has separable measurement transducer (including flow sensor) and calculator (including indicating device)

3.26
flow sensor
volume sensor

that part of the water meter (such as a disc, piston, wheel, turbine element or electromagnetic coil), which senses the flowrate or volume of water passing through the meter

3.27
measurement transducer

part of the meter that transforms the flow or the volume of the water to be measured into signals that are passed to the calculator

NOTE 1 It can be based on a mechanical, electrical or electronic principles. It can be autonomous or use an external power source.

NOTE 2 For the purposes of this part of ISO 4064, the measurement transducer includes the flow or volume sensor.

3.28**calculator**

part of the meter that receives the output signals from the transducer(s) and, possibly, from associated measuring instruments, transforms them into a measurement result and, if appropriate, stores the results in memory until they are used.

NOTE In addition, the calculator can be capable of communicating both ways with ancillary devices

3.29**indicating device**

part of the meter that displays the measurement results, either continuously or on demand

NOTE A printing device, which provides an indication at the end of the measurement, is not an indicating device.

3.30**primary indication**

indication (displayed, printed or memorized) which is subject to legal metrological control

3.31**adjustment device**

device incorporated in the meter, which only allows the error curve to be shifted generally parallel to itself, with a view to bringing relative errors of indication within the maximum permissible errors

3.32**correction device**

device connected to or incorporated in the meter for automatically correcting the volume at metering conditions, by taking into account the flowrate and/or the characteristics of the water to be measured (e.g. temperature and pressure) and the pre-established calibration curves

NOTE The characteristics of the water to be measured can either be measured using associated measuring instruments, or be stored in a memory in the instrument.

3.33**ancillary device**

device intended to perform a particular function, directly involved in elaborating, transmitting or displaying measurement results.

NOTE Main ancillary devices are:

- zero setting device;
- price indicating device;
- repeating indicating device;
- printing device;
- memory device;
- tariff control device;
- pre-setting device;
- self service device.

3.34**associated measuring instruments**

instruments connected to the calculator, the correction device or the conversion device, for measuring certain quantities that are characteristic of water, with a view to making a correction and/or a conversion

3.35**electronic device**

device employing electronic sub-assemblies and performing a specific function

ISO 4064-1:2005(E)

NOTE 1 Electronic devices are usually manufactured as separate units and are capable of being tested independently

NOTE 2 Electronic devices, as defined above, can be complete meters or parts of meters.

3.36

electronic sub-assembly

part of an electronic device, employing electronic components and having a recognizable function of its own

3.37

electronic component

smallest physical entity, which uses electron or hole conduction in semi-conductors, gases, or in a vacuum

3.38

checking facility

facility which is incorporated in a water meter with electronic devices and which enables significant faults to be detected and acted upon

NOTE The checking of a transmission device aims at verifying that all the information that is transmitted (and only that information) is fully received by the receiving equipment.

3.39

automatic checking facility

checking facility operating without the intervention of an operator

3.40

type P permanent automatic checking facility

permanent automatic checking facility operating during the entire measurement operation

3.41

type I intermittent automatic checking facility

intermittent automatic checking facility operating at certain time intervals or per fixed number of measurement cycles

3.42

type N non-automatic checking facility

non-automatic checking facility that requires the intervention of an operator

3.43

power supply device

device, which provides the electronic devices with the required electrical energy, using one or several sources of a.c. or d.c.

3.44

fault

difference between the error of indication and the intrinsic error of a water meter

3.45

significant fault

fault, the magnitude of which is greater than one half of the maximum permissible error in the "upper zone"

NOTE The following are not considered to be significant faults:

- faults arising from simultaneous and mutually independent causes in the water meter itself or in its checking facilities;
- transitory faults being momentary variations in the indication, which cannot be interpreted, memorized, or transmitted as a measurement result.

3.46

influence quantity

quantity that is not the measurand but that affects the result of measurement

3.47**reference conditions**

set of reference values, or reference ranges, of influence quantities, prescribed for testing the performance of a water meter, or for the inter-comparison of the results of measurements

3.48**intrinsic error**

error of indication of a water meter determined under reference conditions

3.49**initial intrinsic error**

intrinsic error of a water meter as determined prior to all performances tests

3.50**influence factor**

influence quantity having a value within the ROC of the water meter, as specified in this part of ISO 4064

3.51**disturbance**

influence quantity having a value within the limits specified in this part of ISO 4064, but outside the specified ROC of the water meter

NOTE An influence quantity is a disturbance if, for that influence quantity, the ROC are not specified.

3.52**first element of the indicating device**

element that, in an indicating device comprising several elements, carries the graduated scale with the verification scale interval

3.53**verification scale interval**

lowest value scale division of the first element of the indicating device

3.54**equipment under test****EUT**

complete water meter, sub-assembly of a water meter or ancillary device

3.53**sub-assembly**

measurement transducer, (including flow sensor) and the indicating device (including calculator) of a combined meter

3.55**test flowrate**

mean flowrate during a test, calculated from the indications of a calibrated reference device, equal to the quotient of the actual volume passing through the water meter divided by the time for that volume to pass through the water meter

3.56**nominal diameter**

alphanumeric designation of size for components of a pipework system, which is used for reference purposes

NOTE It comprises the letters DN followed by a dimensionless whole number that is indirectly related to the physical size in mm of the bore, or outside diameter of the end connections.

3.57
conversion device

device that automatically converts the volume measured at metering conditions into a volume at base conditions, or into a mass, by taking account of the characteristics of the liquid (temperature, pressure, density, relative density) measured using associated measuring instruments, or stored in a memory by an automatic checking facility operating at certain time intervals or per fixed number of measurement cycles

4 Technical characteristics

4.1 In-line meters

4.1.1 Meter size and overall dimensions

Meter size is characterized either by the thread size of the end connections or by the nominal size of the flange. For each meter size there is a corresponding fixed set of overall dimensions. The dimensions of the meter, as illustrated in Figure 1, shall be in accordance with those listed in Table 1.

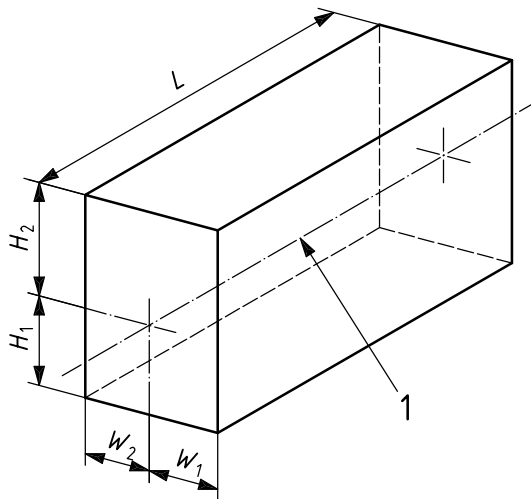

Key

1 pipe axis

NOTE H_1 , H_2 , L , W_1 and W_2 define the height, length and width respectively of a cuboid within which the water meter can be contained (the cover being at right angles to its closed position). H_1 , H_2 , W_1 and W_2 are maximum dimensions. L is a fixed value with specified tolerances.

Figure 1 — Meter size and overall dimensions

Table 1 — Water meter dimensions

Dimensions in millimetres

Size DN ^a	a_{\min}	b_{\min}	L^b (preferred)	L^b (alternatives)	$W_1; W_2$	H_1	H_2
15	10	12	165	80, 85, 100, 105, 110, 114, 115, 130, 134, 135, 145, 170, 175, 180, 190, 200, 220	65	60	220
20	12	14	190	105, 110, 115, 130, 134, 135, 165, 175, 195, 200, 220, 229	65	60	240
25	12	16	260	110, 150, 175, 200, 210, 225, 273	100	65	260
32	13	18	260	110, 150, 175, 200, 230, 270, 300, 321	110	70	280
40	13	20	300	200, 220, 245, 260, 270, 387	120	75	300
50			200	170, 245, 250, 254, 270, 275, 300, 345, 350	135	216	390
65			200	170, 270, 300, 450	150	130	390
80			200	190, 225, 300, 305, 350, 425, 500	180	343	410
100			250	210, 280, 350, 356, 360, 375, 450, 650	225	356	440
125			250	220, 275, 300, 350, 375, 450	135	140	440
150			300	230, 325, 350, 450, 457, 500, 560	267	394	500
200			350	260, 400, 500, 508, 550, 600, 620	349	406	500
250			450	330, 400, 600, 660, 800	368	521	500
300			500	380, 400, 800	394	533	533
350			500	420, 800	270	300	500
400			600	500, 550, 800	290	320	500
500			600	500, 625, 680, 770, 800, 900, 1 000	365	380	520
600			800	500, 750, 820, 920, 1 000, 1 200	390	450	600
800			1 200	600	510	550	700
> 800			1,25 × DN	DN	0,65 × DN	0,65 × DN	0,75 × DN

^a DN: nominal size of flanges and threaded connections

^b Tolerance on length: DN 15 to DN 40 – 0/–2 mm;
DN 50 to DN 300 – 0/–3 mm;
DN 350 to DN 400 – 0/–5 mm.

Tolerances on lengths of meters greater than DN 400 shall be agreed upon between the user and manufacturer.

4.1.2 Threaded connection

Permissible values of dimensions a and b for threaded connections are given in Table 1. Threads shall comply with ISO 228-1. Figure 2 defines dimensions a and b .

4.1.3 Flanged connection

Flanged end connections shall comply with ISO 7005-2 and ISO 7005-3 for the maximum pressure corresponding to that of the water meter. Dimensions shall be as given in Table 1.

The manufacturer shall provide a reasonable clearance behind the rear face of the flange to allow access for installation and removal.

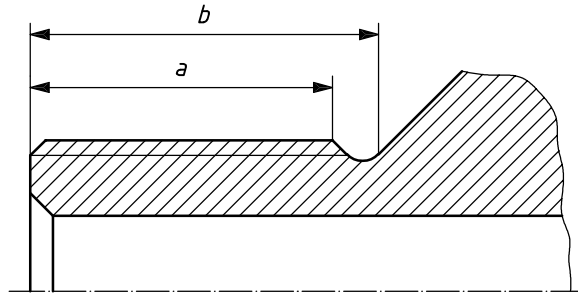

Figure 2 — Threaded connection

4.1.4 Combination meter connection

Dimensions shall be as listed in Table 2.

The overall length of a combination meter may be a fixed dimension or may be adjustable by means of a sliding coupling. In this case, the minimum possible adjustment of the meter overall length shall be ± 15 mm relative to the nominal value of *L* defined in Table 2.

Because of the wide variation in the height of the various types of combination meters, it has not been possible to standardize these dimensions.

Table 2 — Combination water meter with flanged end connections

Dimensions in millimetres

Size DN ^a	<i>L</i> (preferred)	<i>L</i> (alternatives)	<i>W</i> ₁ ; <i>W</i> ₂
50	300	270, 432, 560, 600	220
65	300	650	240
80	350	300, 432, 630, 700	260
100	350	360, 610, 750, 800	350
125	350	850	350
150	500	610, 1 000	400
200	500	1 160, 1 200	400

^a DN: nominal sizes of flange connection.

4.2 Concentric meters

4.2.1 General

This section contains the necessary information on meter size and overall dimensions. The design of two (2) meter manifold connections is found in Annex A. This section and Annex A may be subject to change as concentric water meter and manifold designs evolve.

4.2.2 Meter size and overall dimensions

Dimensions for a current meter design are shown in Figure 3 and Table 3.

4.2.3 Design of the meter manifold connection

The meter connection shall be designed to connect the meter, using the screw thread provided, to a manifold having this design of face. Suitable seals shall ensure that no leaks occur between the inlet connection and the meter/manifold exterior or between the inlet and outlet passages at the meter/manifold interface.

4.2.4 Dimensions of concentric meters

Dimensions for concentric meters are defined by a cylinder into which the meter fits (see Figure 3 and Table 3).

NOTE Where there is a separate indicating device or calculator, the overall size specified in Figure 3 applies only to the housing of the measurement transducer.

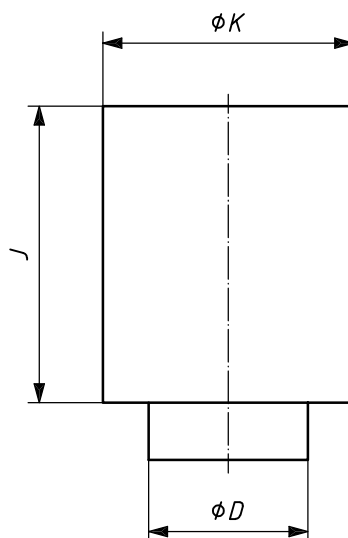

Figure 3 — Concentric meter dimensions

Table 3 — Concentric meter dimensions

Maximum dimensions in millimetres

Type	D^a	J^b	ϕK^b
1	(G 1½ B)	220	110
2	(G 2 B)	220	135
3	(M62 × 2)	220	135
^a Metric or Whitworth threading at the discretion of the manufacturer. ^b J and K define respectively the height and diameter of a cylinder enclosing the meter.			

4.3 Pressure loss

The maximum pressure loss within rated operating conditions, ROC, shall not exceed 0,063 MPa (0,63 bar). This includes any filter or strainer that is part of the meter.

The pressure loss class shall be selected by the manufacturer from the values of the R-5 series of ISO 3:1973 as indicated in Table 4.

Concentric meters, of any type and measuring principle, shall be tested together with an appropriate manifold.

Table 4 — Pressure-loss classes

Class	Maximum pressure loss	
	MPa	bar
Δp 63	0,063	0,63
Δp 40	0,040	0,40
Δp 25	0,025	0,25
Δp 16	0,016	0,16
Δp 10	0,010	0,10

5 Metrological requirements

5.1 Metrological characteristics

5.1.1 Meter designation and permanent flowrate (Q_3)

Water meters are designated according to the permanent flowrate Q_3 in cubic metres per hour and ratio of Q_3 to the minimum flowrate Q_1 .

The numerical value of the permanent flowrate Q_3 , expressed in cubic metres per hour (m^3/h) shall be chosen either:

a) from line R 5 of ISO 3:1973, thus:

1,0	1,6	2,5	4,0	6,3
10	16	25	40	63
100	160	250	400	630
1 000	1 600	2 500	4 000	6 300

(this list may be extended to higher or lower values in the series) or

b) from the following values: (1,5); (3,5); (6); (15); (20).

NOTE It is intended that the values permitted in b) will be removed from this part of ISO 4064 after a transition period ending on 30 April 2009.

5.1.2 Measuring range

The measuring range for the flowrate is defined by the ratio Q_3/Q_1 . Values of Q_3/Q_1 shall be chosen either:

a) from line R 10 from ISO 3:1973, thus:

10	12,5	16	20	25	31,5	40	50	63	80
100	125	160	200	250	315	400	500	630	800

(this list may be extended to higher values in the series) or

b) from the following values: (15); (35); (60); (212).

NOTE It is intended that the values permitted in b) will be removed from this this part of ISO 4064 after a transition period ending on 30 April 2009.

5.1.3 Relationship between permanent flowrate (Q_3) and overload flowrate (Q_4)

The overload flowrate is defined by:

$$Q_4/Q_3 = 1,25$$

5.1.4 Relationship between transitional flowrate (Q_2) and minimum flowrate (Q_1)

The transitional flowrate shall be determined according to either:

- a) $Q_2/Q_1 = 1,6$ or
- b) $Q_2/Q_1 = (1,5); (2,5); (4); (6,3)$, provided $Q_3/Q_2 > 5$

NOTE It is intended that the values permitted in b) will be removed from this part of ISO 4064 after a transition period ending on 30 April 2009.

5.1.5 Reference flowrate

The flowrate to be used as reference flowrate is defined by the following formula:

$$\text{reference flowrate} = 0,7 \times (Q_2 + Q_3) \pm 0,03 \times (Q_2 + Q_3);$$

5.2 Maximum permissible error

5.2.1 Maximum permissible error in service

The maximum permissible errors of a water meter while in service shall be twice the maximum permissible errors given in 5.2.3 and 5.2.4.

5.2.2 Relative error (ε)

The relative error is expressed as a percentage, and is equal to:

$$\varepsilon = \frac{(V_i - V_a)}{V_a} \times 100$$

where

V_i is the indicated volume;

V_a is the actual volume.

5.2.3 MPE lower flow range

The maximum permissible error, positive or negative, on volumes delivered at flowrates between the minimum flowrate (Q_1) and the transitional flowrate (Q_2) (excluded) is 5 % for water having a temperature within ROC.

5.2.4 MPE upper flow range

The maximum permissible error, positive or negative, on volumes delivered at flowrates between the transitional flowrate (Q_2) (included) and the overload flowrate (Q_4) is:

- 2 % for water having a temperature ≤ 30 °C;
- 3 % for water having a temperature > 30 °C.

5.2.5 Sign of the error

If all the errors within the measuring range of the water meter have the same sign, at least one of the errors shall be less than one half of the maximum permissible error (MPE).

5.2.6 Reverse flow

The manufacturer shall specify whether the meter is designed to measure reverse flow. If it is, the reverse flow volume shall either be subtracted from the indicated volume, or shall be separately recorded. The same MPE shall apply to both forward and reverse flow.

Water meters not designed to measure reverse flow shall either prevent it or shall be capable of withstanding an accidental reverse flow without any deterioration or change in metrological properties for forward flow.

5.2.7 Temperature and pressure variations MPE requirements

The requirements relating to MPE shall be met for all temperature and pressure variations occurring within the ROC of the water meter.

5.2.8 Water meters with separate calculator and measurement transducer

The calculator and measurement transducer of a water meter, where they are separable and interchangeable with other calculators and measurement transducers of the same or different designs, may be the subject of separate pattern approvals.

The maximum permissible errors of the combined calculator and measurement transducer shall not exceed the values given in 5.2.3 and 5.2.4.

5.3 Zero flow totalization

The water meter totalization shall not change when the flowrate is zero.

5.4 Rated operating conditions (ROC)

5.4.1 Meter temperature classes

Meters shall be classified by water temperature range, chosen by the manufacturer in accordance with Table 5.

The water temperature shall be measured at the inlet of the meter.

Table 5 — Temperature classes

Class	mAT (°C)	MAT (°C)	Reference condition (°C)
T30	0,1	30	20
T50	0,1	50	20
T70	0,1	70	20 and 50
T90	0,1	90	20 and 50
T130	0,1	130	20 and 50
T180	0,1	180	20 and 50
T30/70	30	70	50
T30/90	30	90	50
T30/130	30	130	50
T30/180	30	180	50

5.4.2 Meter pressure classes

5.4.2.1 Admissible water pressure

The water pressure shall be measured upstream of the meter inlet for MAP evaluation and downstream of the meter outlet for mAP evaluation.

The minimum admissible pressure, mAP, shall be 30 kPa (0,3 bar).

The meters form maximum admissible pressure classes corresponding to the various MAP values of the following ISO series, chosen by the manufacturer, as shown in Table 6.

Table 6 — Water pressure classes

Class	MAP MPa (bar)	Reference condition MPa (bar)
MAP 6 ^a	0,6 (6)	0,2 (2)
MAP 10	1,0 (10)	0,2 (2)
MAP 16	1,6 (16)	0,2 (2)
MAP 25	2,5 (25)	0,2 (2)
MAP 40	4,0 (40)	0,2 (2)

^a For DN ≥ 500.

5.4.2.2 Internal pressure

The water meter shall be able to withstand the internal pressure according to the respective class derived from Table 6. This shall be tested according to the corresponding test as laid down in ISO 4064-3.

5.4.2.3 Concentric meters

The requirement in 5.4.2.2 also applies to pressure testing of concentric water meters; however the seal is located at the concentric meter/manifold interface. This shall also be tested to ensure that undisclosed internal leaks between the inlet and outlet passages of the meter do not occur.

When the pressure loss test is carried out, the meter and manifold shall be tested together.

5.4.3 Working pressure range

Water meters shall operate up to a working pressure range of at least 1 MPa (10 bar), except for meters having pipe size of 500 mm or above in which the working water pressure range shall be at least 0,6 MPa (6 bar).

5.4.4 Ambient temperature working range

Water meters shall operate over the ambient temperature range + 5 °C to + 55 °C. Meters with electronic devices and class 3 severity level shall operate over the ambient temperature range – 25 °C to + 55 °C.

5.4.5 Ambient humidity working range

The ambient humidity range for water meters is 0 % to 100 % at 40 °C and at least 93 % at 40 °C for remote reading devices.

5.4.6 Power source working range

Electric or electronic water meters and water meters with electronic devices which require an external power supply shall operate over a voltage range of – 15 % to + 10 % of the nominal a.c. or d.c. voltage source and ± 2 % of the nominal frequency of an a.c. power source.

5.5 Flow profile sensitivity classes

The water meter shall be able to withstand the influence of abnormal velocity fields as defined in the test procedures in ISO 4064-3. During the application of these flow disturbances the error of indication shall meet the requirements of 5.2.1 to 5.2.4.

The meter manufacturer shall specify the flow profile sensitivity class in accordance with the classifications given in Tables 7 and 8, based on the results of the relevant tests specified in ISO 4064-3.

Any flow conditioning section, including straightener and/or straight lengths, to be used shall be entirely defined by the manufacturer and is considered to be an auxiliary device linked to the type of meter examined. The manufacturer shall provide the suitable straighteners and straight lengths, which will make up an integral part of pattern approval.

**Table 7 — Sensitivity to the irregularity
in the upstream velocity fields classes (U)**

Class	Required straight lengths (× DN)	Straightener needed
U0	0	No
U3	3	No
U5	5	No
U10	10	No
U15	15	No
U0S	0	Yes
U3S	3	Yes
U5S	5	Yes
U10S	10	Yes

**Table 8 — Sensitivity to the irregularity
in the downstream velocity fields classes (D)**

Class	Required straight lengths (× DN)	Straightener needed
D0	0	No
D3	3	No
D5	5	No
D0S	0	Yes
D3S	3	Yes

5.6 Requirements for electronic meters and meters with electronic devices

5.6.1 Adjustment device

Meters may be provided with an adjustment device.

5.6.2 Correction device

Meters may be fitted with correction devices; such devices are always considered as an integral part of the meter. The whole of the requirements which apply to the meter, in particular the maximum permissible errors specified in 5.2, are therefore applicable to the corrected volume at metering conditions.

In normal operation, non-corrected volume shall not be displayed.

The aim of a correction device is to reduce the errors as close to zero as possible. Water meters with correction devices have to satisfy the performance tests of 6.7.3.

All the parameters which are not measured and which are necessary for correcting shall be contained in the calculator at the beginning of the measurement operation. The pattern approval certificate may prescribe the possibility of checking parameters, which are necessary for correctness at the time of verification of the correction device.

The correction device shall not allow the correction of a pre-estimated drift, e.g., in relation to time or volume.

The associated measuring instruments, if any, shall comply with the applicable International Standards or recommendations. Their accuracy shall permit the requirements on the meter to be met, as specified in 5.2.

Associated measuring instruments shall be fitted with checking devices, as specified in C.5.

Correction devices shall not be used for adjusting the errors of indication of a water meter to values other than as close as practical to zero, even when these values are within the maximum permissible errors.

5.6.3 Calculator

All parameters necessary for the elaboration of indications that are subject to legal metrological control, such as a calculation table or correction polynomial, shall be present in the calculator at the beginning of the measurement operation.

The calculator may be provided with interfaces permitting the coupling of peripheral equipment. When these interfaces are used, the water meter's hardware and software shall continue to function correctly and its metrological functions shall not be capable of being affected.

5.6.4 Electronic indicating device

The continuous display of volume during the period of measurement is not mandatory. However, interruption of the display shall not interrupt the action of checking facilities, if present.

5.6.5 Ancillary devices

The relevant requirements of section 5.2 shall be applied, when the water meter is equipped with any of the following devices:

- zero setting device;
- price indicating device;
- printing device;
- memory device;
- pre-setting device;
- self-service device.

These devices may be used to detect movement of the measuring device before this is clearly visible on the indicating device.

Where national regulations permit, the device may be used as a control element for testing and verification and for remote reading of the water meter, provided that other means guarantee the satisfactory operation of the water meter in accordance with the requirements of 5.2.

Such a device could also be employed for remote reading of the water meter. The addition of these devices, either temporary or permanent, shall not alter the metrological characteristics of the meter.

6 Technical requirements

6.1 Requirements for materials and construction of water meters

6.1.1 The water meter shall be manufactured from materials of adequate strength and durability for the purpose for which the water meter is to be used.

6.1.2 The water meter shall be manufactured from materials that shall not be adversely affected by the water temperature variations, within the working temperature range (see 5.4.1).

6.1.3 All parts of the water meter in contact with the water flowing through it shall be manufactured from materials that are conventionally known to be non-toxic, non-contaminating and biologically inert

NOTE National regulations can apply.

6.1.4 The complete water meter shall be manufactured from materials that are resistant to internal and external corrosion, or that are protected by a suitable surface treatment.

6.1.5 The water meter indicating devices shall be protected by a transparent window. A cover of suitable type may also be provided as additional protection.

6.1.6 The water meter shall incorporate devices for removal of condensation, where there is a risk of the condensation forming on the underside of the window of the water meter-indicating device.

6.2 Endurance

It shall be demonstrated that the water meter is able to fulfil the appropriate endurance requirements according to the permanent flowrate, Q_3 , and the overload flowrate, Q_4 , of the meter, simulating service conditions, as listed in Table 1 of ISO 4064-3:2005. For meters designed to measure reverse flow the requirements apply to both flow directions.

6.3 Adjustment of water meters

The water meter may be fitted with an adjustment device, that allows shifting of the error curve generally parallel to itself with a view to bringing errors within MPE.

If the adjustment device is mounted on the outside of the water meter, provision for sealing shall be made (see 6.4).

6.4 Verification marks and protection devices

A place shall be provided on water meters for the main verification mark, which shall be visible without dismantling the water meter.

Water meters shall include protection devices that can be sealed so as to ensure that, both before and after correct installation of the water meter, dismantling or modification of the meter and/or its adjustment device or correction device is not possible without damaging these devices.

6.5 Electronic sealing devices

6.5.1 Access

6.5.1.1 When access to parameters that influence the determination of the results of measurements is not protected by mechanical sealing devices, the protection shall fulfil the provisions of 6.5.1.2 and 6.5.1.3.

6.5.1.2 Access shall only be allowed to authorized people, e.g. by means of a code (key-word) or of a special device (e.g. a hard key). The code shall be capable of being changed.

6.5.1.3 At least the last intervention shall be memorized. The record shall include the date and a characteristic element identifying the authorized person making the intervention. The traceability of the last intervention shall be assured for at least two years, if it is not overwritten on the occasion of a further intervention. If it is possible to memorize more than one intervention and if deletion of a previous intervention has to occur to permit a new record, the oldest record shall be deleted.

6.5.2 Exchangeable parts

6.5.2.1 For meters with parts which may be disconnected one from another by the user and which are inter-changeable, the provisions of 6.5.2.2 and 6.5.2.3 shall be fulfilled.

6.5.2.2 It shall not be possible to modify parameters that participate in the determination of results of measurements through disconnected points unless the provisions in 6.5.1 are fulfilled.

6.5.2.3 Interposing any device which may influence the accuracy shall be prevented by means of electronic and data processing securities or, if this is not possible, by mechanical means.

6.5.3 Disconnection of parts

For meters with parts that may be disconnected, one from another, by the user and which are not interchangeable, the provisions in 6.5.2 shall apply. Moreover, these meters shall be provided with devices that do not allow them to operate if the various parts are not connected according to the manufacturer's configuration.

NOTE Disconnections that are not allowed by the user may be prevented, e.g. by means of a device that prevents any measurement after disconnecting and reconnecting.

6.6 Indicating device

6.6.1 General requirements

6.6.1.1 Function

The indicating device of the water meter shall provide an easily read, reliable and unambiguous visual indication of the indicated volume.

The indicating device shall include visual means for testing and calibration.

The indicating device may include additional elements for testing and calibration by other methods, e.g. for automatic testing and calibration.

6.6.1.2 Unit of measurement, symbol and placement

The indicated volume of water shall be expressed in cubic metres. The unit m³ shall appear on the dial immediately adjacent to the numbered display.

6.6.1.3 Indicating range

The indicating range of the meter shall conform to the requirements of Table 9.

Table 9 — Indicating range of a water meter

Q_3 (m ³ /h)	Indicating range (minimum values) (m ³)
$Q_3 \leq 6,3$	9 999
$6,3 < Q_3 \leq 63$	99 999
$63 < Q_3 \leq 630$	999 999
$630 < Q_3 \leq 6\,300$	9 999 999

6.6.1.4 Colour coding for indicating devices

The colour black shall preferably be used to indicate the cubic metre and its multiples.

The colour red shall preferably be used to indicate sub-multiples of a cubic metre.

These colours shall be applied to either the pointers, indexes, numbers, wheels, discs, dials or aperture frames.

Other means of indicating the cubic metre, its multiples and its submultiples may be used provided there is no ambiguity in distinguishing between the indication and alternative display, e.g. submultiples for verification and testing.

6.6.2 Types of indicating device

6.6.2.1 General

Any of the types of indicating device described in 6.6.2.2 to 6.6.2.4 shall be used.

6.6.2.2 Type 1 — analogue device

The volume shall be indicated by continuous movement of:

- a) one or more pointers moving relative to graduated scales;
- b) one or more circular scales or drums each passing an index.

The value expressed, in cubic metres, for each scale division shall be of the form 10^n , where n is a positive or negative whole number or zero, thereby establishing a system of consecutive decades. Each scale shall be either graduated in values expressed in cubic metres or accompanied by a multiplying factor ($\times 0,001$; $\times 0,01$; $\times 0,1$; $\times 1$; $\times 10$; $\times 100$; $\times 1\,000$; etc.).

Linear movement of pointers or scales shall be left to right.

Rotational movement of the pointers or circular scales shall be clockwise.

Movement of numbered roller indicators (drums) shall be upwards.

6.6.2.3 Type 2 — digital device

The volume shall be indicated by a line of adjacent digits appearing in one or more apertures. Movement of numbered roller indicators (drums) shall be upwards.

The advance of any given digit shall be completed while the digit of the next immediately lower decade changes from 9 to 0.

The lowest value decade may have a continuous movement, the aperture being large enough to permit a digit to be read unambiguously.

The apparent height of the digits shall be at least 4 mm.

6.6.2.4 Type 3 — combination of analogue and digital devices

The volume shall be indicated by a combination of type 1 and type 2 devices and the respective requirements of each shall apply.

6.6.3 Verification devices — First element — Verification scale interval

6.6.3.1 First element and verification scale interval

The indicator having the lowest valued decade is called the first element. Its lowest value scale division is called the verification scale interval.

Every indicating device shall provide means for visual, non-ambiguous verification testing and calibration through the first element.

The visual verification display may have either a continuous or a discontinuous movement.

In addition to the visual verification display, an indicating device may include provisions for rapid testing by the inclusion of complementary elements (e.g. star wheels or discs), providing signals through externally attached sensors.

6.6.3.2 Visual verification displays

6.6.3.2.1 Value of the verification scale interval

The value of the verification scale interval, expressed in cubic metres, shall be based on the formula: 1×10^n or 2×10^n or 5×10^n , where n is a positive or negative whole number, or zero.

For analogue and digital indicating devices with continuous movement of the control element, the verification scale may be formed from the division into 2, 5 or 10 equal parts of the interval between two consecutive digits of the control element. Numbering shall not be applied to these divisions.

For digital indicating devices with discontinuous movement of the control element the verification scale interval is the interval between two consecutive digits or incremental movements of the control element

6.6.3.2.2 Form of the verification scale

On indicating devices with continuous movement of the control element, the apparent scale spacing shall not be less than 1 mm and not more than 5 mm. The scale shall consist of either:

- lines of equal thickness not exceeding one-quarter of the scale spacing and differing only in length;
- or
- contrasting bands of a constant width equal to the scale spacing.

—————

The apparent width of the pointer at its tip shall not exceed one-quarter of the scale spacing and in no case shall it be greater than 0,5 mm.

6.6.3.2.3 Resolution of the indicating device

The sub-divisions of the verification scale shall be small enough to ensure that the resolution of the reading of the meter does not exceed 0,5 % of the actual volume during the test at the minimum flowrate Q_1 and the test shall not take more than 1 h 30 min. This requirement applies to both mechanical and electronic registers.

When the display of the first element is continuous, an allowance shall be made for a possible reading error in each reading, of not more than half of the smallest scale division.

When the display of the first element is discontinuous, an allowance shall be made, for a possible reading error in each reading, of one digit.

6.6.3.3 Additional verification elements

Additional verification elements may be used provided that the uncertainty of reading is not greater than 0,5 % of the test volume and that the correct functioning of the indicating device is checked.

6.7 Water meters equipped with electronic devices

6.7.1 General requirements

Water meters with electronic devices shall be designed and manufactured in such a way that significant faults do not occur when they are exposed to the disturbances specified in ISO 4064-3. Also, they shall be designed and manufactured such that errors do not exceed the maximum possible errors as defined in 5.4 under ROC.

6.7.2 Checking facilities

In addition to complying with the performance tests specified in ISO 4064-3, meters equipped with checking facilities shall pass a design inspection.

Checking facilities are only mandatory for meters used for prepayment or for water meters which are not permanently installed for a customer.

NOTE Depending on national regulations, or their functions, permanently installed prepayment meters may or may not be subjected to this requirement on checking facilities; e.g. checking facilities are not mandatory for domestic water meters not used for prepayment.

The requirements for checking facilities are laid down in Annex C.

Water meters not equipped with checking facilities are presumed to comply with the requirements in 6.7.1, if they pass the design inspection and performance tests specified in ISO 4064-3 under the following conditions:

- five identical meters are submitted at pattern approval;
- at least one of these five meters is submitted to the whole set of tests;
- no meter fails at any test.

6.7.3 Electronic indicating device

The totalizing device shall provide a reliable, clear and unambiguous reading of the volume of water measured.

A non-permanent display is permitted, even during measuring, however it shall be possible to display the volume upon request at any time. If the display is non-permanent, the volume indication time shall be at least ten seconds.

When the totalizing device is capable of displaying additional information, this information shall be displayed without ambiguity.

NOTE This condition could be satisfied if, e.g., an extra indication indicates the exact nature of the further information currently displayed, or if each display is controlled by a separate button.

A feature shall be included which enables the correct operation of the display to be checked, e.g. by successive display of the various characters. Each step of the sequence shall last at least one second.

The decimal part of the reading expressed in cubic metres need not necessarily be displayed on the same displaying device as the whole unit part. In such a case, the reading shall be clear and without ambiguity (an extra indication of flow shall be displayed on the indicator).

The value may be read, e.g.:

- using two separate displaying devices on the totalizing device;
- in two successive steps on the same displaying device;
- using a removable indicating device enabling the decimal part display to be read; in such a case a permanent device shall show that the meter is counting with a suitable resolution and the manufacturer shall provide information on the meter about the approximate resolution of this permanent indicating device.

6.7.4 Power supply

6.7.4.1 General

Three different kinds of basic power supplies for water meters with electronic devices are covered by this part of ISO 4064:

- external power supply;
- non-replaceable battery;
- replaceable battery.

These three types of power supply may be used alone or in combination. The requirements for each type of power supply are covered by 6.7.4.2 to 6.7.4.4.

6.7.4.2 External power supply

6.7.4.2.1 Water meters with electronic devices shall be so designed, that in event of an external power supply failure (a.c. or d.c.), the meter indication of volume just before failure is not lost, and remains accessible for a minimum of one year.

The corresponding memorization shall occur at least either once per day or for every volume equivalent to 10 min of flow at Q_3 .

6.7.4.2.2 Any other properties or parameters of the meter shall not be affected by an interruption of the electrical supply.

NOTE Compliance with this clause will not necessarily ensure that the water meter will continue to register the volume consumed during a power supply failure.

An internal battery shall ensure that the meter operates for at least one month in total when external power supply failure occurs, under normal metering conditions. The lifetime of this battery, allowing for the number of years idle and the one month of usage in the event of the external power supply failure, corresponding to the number of years of stockage plus one month of functioning, shall be indicated on the meter.

6.7.4.2.3 The power supply shall be capable of being securely protected from tampering.

6.7.4.3 Non-replaceable battery

The manufacturer shall ensure that the indicated lifetime of the battery guarantees that the meter functions correctly for at least one year longer than the operational lifetime of the meter.

NOTE It is anticipated that a combination of maximum permissible volume, displayed volume, indicated operational lifetime, remote reading and extreme temperature will be considered when specifying a battery and during pattern approval.

6.7.4.4 Replaceable battery

6.7.4.4.1 Where the electrical power supply is a replaceable battery, the manufacturer shall give precise rules for the replacement of the battery.

6.7.4.4.2 The replacement date of the battery shall be indicated on the meter. The replacement of the battery shall be indicated on the meter and provide the possibility of indicating the next date of replacement after replacing the battery.

6.7.4.4.3 The properties and parameters of the meter shall not be affected by the interruption of the electrical supply when the battery is replaced. This requirement will not necessarily ensure that the meter will continue to register the water volume consumed whilst the battery is being replaced. This shall be tested according to the corresponding test as laid down in ISO 4064-3.

NOTE It is anticipated that a combination of maximum permissible volume, displayed volumes, remote reading and temperature will be considered when specifying a battery and during pattern approval. Shelf life and non-operational discharge can also be considered.

6.7.4.4.4 The operation of replacing the battery may be carried out in a way that does not necessitate breaking the statutory metrological seal. When the battery can be removed without breaking the statutory seal the battery compartment shall be protected by a tamper proof device, such as a seal authorized by the meter manufacturer or controlling authority. Alternatively, where the breaking of the statutory metrological seal is necessary in order to replace the battery, the national metrology body may require that the replacement of the seal be undertaken either by itself or another approved body.

6.7.5 Performance tests for water meters with electronic devices

6.7.5.1 General

This section defines the programme of performance tests intended to verify that water meters with electronic devices may perform and function as intended in a specified environment and under specified conditions. Each test indicates, where appropriate, the reference conditions for determining the intrinsic error.

These tests supplement any other prescribed test.

When the effect of one influence quantity is being evaluated, all other influence quantities are to be held relatively constant, at values close to reference conditions (see 6.7.5.3).

6.7.5.2 Severity levels

For each performance test, typical test conditions are indicated, which correspond to the climatic and mechanical environmental conditions to which water meters are usually exposed.

Water meters with electronic devices are divided into three classes according to climatic and mechanical environmental conditions:

— class B for fixed meters installed in a building;

- class C for fixed meters installed outdoors;
- class I for mobile meters.

However, the applicant for pattern approval may indicate specific environmental conditions in the documentation supplied to the metrology service, based on the intended use of the instrument. In this case, the metrology service carries out performance tests at severity levels corresponding to these environmental conditions. If pattern approval is granted, the data plate shall indicate the corresponding limits of use. Manufacturers shall inform potential users of the conditions of use for which the meter is approved. The metrology service shall verify that the conditions of use are met.

Water meters with electronic devices are divided into two electromagnetic environment classes:

- Class E1 Residential, commercial and light industrial;
- Class E2 Industrial.

6.7.5.3 Reference conditions

Reference conditions for the performance tests shall be as follows:

Ambient air temperature:	20 °C ± 5 °C
Ambient relative humidity:	60 % ± 15 %
Ambient atmospheric pressure:	86 kPa to 106 kPa
Power voltage:	Nominal voltage (U_{nom}) ± 5 %
Power frequency:	Nominal frequency (f_{nom}) ± 2 %
Water	See 5.4.1 (± 5 °C)

During each test, the temperature and relative humidity shall not vary by more than 5 °C or 10 % respectively within the reference range.

6.7.5.4 Pattern approval of an electronic calculator

When an electronic calculator is submitted for separate pattern approval, pattern approval tests are conducted on the calculator alone, simulating different inputs with appropriate standards.

Accuracy tests include an accuracy test on the indications of measurement results. For this purpose, the error obtained on the indication of the result is calculated considering that the true value is the one which takes into account the value of the simulated quantities applied to inputs of the calculator and using standard methods for calculation. The maximum permissible errors are those fixed in 5.2.

6.7.5.5 Performance tests

6.7.5.5.1 General

The tests shall be carried out in accordance with the applicable clause(s) of ISO 4064-3. The tests listed in Table 10 and described in 6.7.5.5.2 to 6.7.5.5.13 involve the electronic part of the water meter or its devices and may be carried out in any order.

NOTE 6.7.5.5.2 to 6.7.5.5.13 describe the test methods that are to be applied and the object of the test in each case. For information, cross-reference to relevant standards is included in each subclause. However, it should be noted that normative reference is made to most or all of these standards in ISO 4064-3.

Table 10 — Performance tests

Subclause	Test	Nature of the influence quantity	Severity level for the class (see OIML D 11)		
			B	C	I
6.7.5.5.2	Dry heat	Influence factor	3	3	3
6.7.5.5.3	Cold	Influence factor	1	3	3
6.7.5.5.4	Damp heat, cyclic	Influence factor	1	2	2
6.7.5.5.5	Power supply variation	Influence factor	1	1	1
6.7.5.5.6	Vibration (random)	Disturbance	—	—	2
6.7.5.5.7	Mechanical shock	Disturbance	—	—	1
6.7.5.5.8	Short time power reductions	Disturbance	1a and 1b	1a and 1b	1a and 1b
6.7.5.5.9	Bursts	Disturbance	2	2	2
6.7.5.5.10	Electrostatic discharge	Disturbance	1	1	1
6.7.5.5.11	Electromagnetic susceptibility	Disturbance	2,5,7	2,5,7	2,5,7
6.7.5.5.12	Static magnetic field	Influence factor	—	—	—
6.7.5.5.13	Surge immunity	Disturbance	2	2	2

The following rules shall be taken into consideration for these performance tests:

- 1) **Test volumes:** some influence quantities should have a constant effect on measurement results and not a proportional effect related to the measured volume. The value of the significant fault is related to the measured volume; therefore, in order to be able to compare results obtained in different laboratories, it is necessary to perform a test on a volume corresponding to that delivered in one minute at the over-load flowrate Q_4 . Some tests, however, may require more than one minute, in which case they shall be carried out in the shortest possible time taking into consideration the measurement uncertainty.
- 2) **Influence of the water temperature:** temperature tests concern the ambient temperature and not the temperature of the water used. It is therefore advisable to use a simulation test method so that the temperature of the water does not influence the test results.

6.7.5.5.2 Dry heat

Test method:	Dry heat (non condensing)
Object of the test:	To verify compliance with the provisions in 5.2 under conditions of high ambient air temperature.
References:	IEC 60068-2-2:1974, am 1:1993, am 2:1994 [1] IEC 60068-3-1:1974, am 1:1978 [2] IEC 60068-1:1988, am 1:1992 [3]

6.7.5.5.3 Cold

Test method:	Cold
Object of the test:	To verify compliance with the provisions in 5.2 under conditions of low ambient air temperature.
References:	IEC 60068-2-1:1974, am 1:1993, am 2:1994 [4] IEC 60068-3-1:1974, am 1:1978 [2] IEC 60068-1:1988, am 1:1992 [3]

6.7.5.5.4 Damp heat, cyclic

Test method:	Damp heat, cyclic (condensing)
Object of the test:	To verify compliance with the provisions in 5.2 under conditions of high humidity when combined with cyclic temperature changes.
References:	IEC 60068-2-30:1980, am 1:1985 [5] IEC 60068-3-4:2001 [6]

6.7.5.5.5 Power supply variation

6.7.5.5.5.1 Water meters powered by direct a.c. or a.c./d.c. converters

Test method:	Variation in a.c. mains power supply (single phase)
Object of the test:	To verify compliance with the provisions in 5.2 under conditions of varying a.c. mains power supply.
References:	IEC 61000-4-11:2004 [7]

6.7.5.5.5.2 Water meters powered by primary batteries

Test method:	Variation in d.c. primary battery power supply
Objective of the test:	To verify compliance with the provisions in 5.2 under conditions of varying d.c. power supply.
References:	None available

6.7.5.5.6 Vibration (random)

Test method:	Random vibration
Object of the test:	To verify compliance with the provisions in 5.2 under conditions of sinusoidal vibration. This test should normally apply to mobile installations only.
References:	IEC 60068-2-64:1993 [8] IEC 60068-2-47:2005 [9]

6.7.5.5.7 Mechanical shock

Test method:	Provide a known mechanical shock
Object of the test:	To verify compliance with the provisions in 5.2 after the application of a mechanical shock.
References:	IEC 60068-2-31:1969 [10] IEC 60068-2-47:2005 [9]

6.7.5.5.8 Short time power reductions

Test method:	Short time interruptions and reductions in mains voltage
Object of the test:	To verify compliance with the provisions in 5.2 under conditions of short time mains voltage interruptions and reductions.
References:	IEC 61000-4-11:2004 [7]

6.7.5.5.9 Bursts

Test method:	Electrical bursts
Object of the test:	To verify compliance with the provisions in 5.2 under conditions where electrical bursts are superimposed on the mains voltage.
References:	IEC 61000-4-4:1995, am 1:1998 [11]

6.7.5.5.10 Electrostatic discharge

Test method:	Electrostatic discharge
Object of the test:	To verify compliance with the provisions in 5.2 under conditions of direct and indirect electrostatic discharges.
References:	IEC 61000-4-2:1995, am 1:1998 [12]

6.7.5.5.11 Electromagnetic susceptibility

Test method:	Electromagnetic fields (radiated)
Object of the test:	To verify compliance with the provisions in 5.2 under conditions of electromagnetic fields.
References:	IEC 61000-4-3:2002 [13]

6.7.5.5.12 Static magnetic field

Test method:	Static magnetic fields
Object of the test:	To verify compliance with the provisions in 5.2 under conditions of static magnetic fields.
References:	ISO 4064-3.

6.7.5.5.13 Surge immunity

Test method:	Application of surge transient voltages
Object of the test:	To verify compliance with the provisions in 5.2 under conditions where surge transients are superimposed.
References:	IEC 61000-4-5:2001 [14]

6.8 Descriptive markings

The water meter shall be clearly and indelibly marked with the following information, either grouped or distributed on the casing, the indicating device dial, an identification plate, or on the meter cover if it is not detachable:

- unit of measurement: cubic metre (see 6.6.1.2);
- value of Q_3 , Q_3/Q_1 , Q_2/Q_1 (if not equal to 1,6), and the pressure loss class [where it differs from $\Delta p = 0,063$ MPa (0,63 bar)];

e.g.: $Q_3 = 25$, $Q_3/Q_1 = 200$, $Q_2/Q_1 = 2,5$, $\Delta p 10$

where: $Q_3 = 25$ m³/h

$Q_3/Q_1 = 200$ (can be represented as R200)

$Q_2/Q_1 = 2,5$

$\Delta p 10 = 0,01$ MPa (0,1 bar)

- name or trademark of the manufacturer;
- year of manufacture and serial number (as near as possible to the indicating device);
- direction of flow (shown on both sides of the body, or on one side only provided the direction of flow arrow will be easily visible under all circumstances);
- maximum admissible pressure if it exceeds 1 MPa (10 bar) or, for $DN \geq 500$, 0,6 MPa (6 bar);
- letter V or H, if the meter can only be operated in the vertical or horizontal position;
- temperature class, where it differs from T30;
- pattern approval sign according to national regulations;

- classes on sensitivity to irregularities in the velocity field²⁾;
- climatic and mechanical environmental security level²⁾;
- EMC class²⁾;
- output signals for ancillary devices (type/levels) if any.

For water meters with electronic devices, the following inscriptions are necessary:

- for an external power supply, the voltage and frequency;
- for a replaceable battery, the latest date that the battery is to be replaced;
- for a non-replaceable battery, the latest date that the meter has to be replaced.

2) This information can be given on a separate data sheet, unambiguously related to the meter by a unique identification.

Annex A (informative)

Concentric water meter manifold

A.1 General

An ISO standard for the connections to concentric water meters does not currently exist. This annex contains the necessary information to design and construct the meter manifold connection and references any relevant sources of information. This annex will be expanded as other manifold designs are submitted for inclusion.

A.2 Concentric water meter manifold design [15]

The design of two manifold interfaces is shown in Figures A.1 and A.2 (see also Table 3).

The meter connection should be designed to connect the meter, using the screw thread provided, to a manifold having this design of face. Suitable seals should ensure that no leaks occur between the inlet connection and the meter/manifold exterior or between the inlet and outlet passages at the meter/manifold interface.

NOTE ISO 4064-3 refers to the additional pressure tests to be passed by this meter type.

.....

Dimensions in millimetres
Surface roughness in micrometres

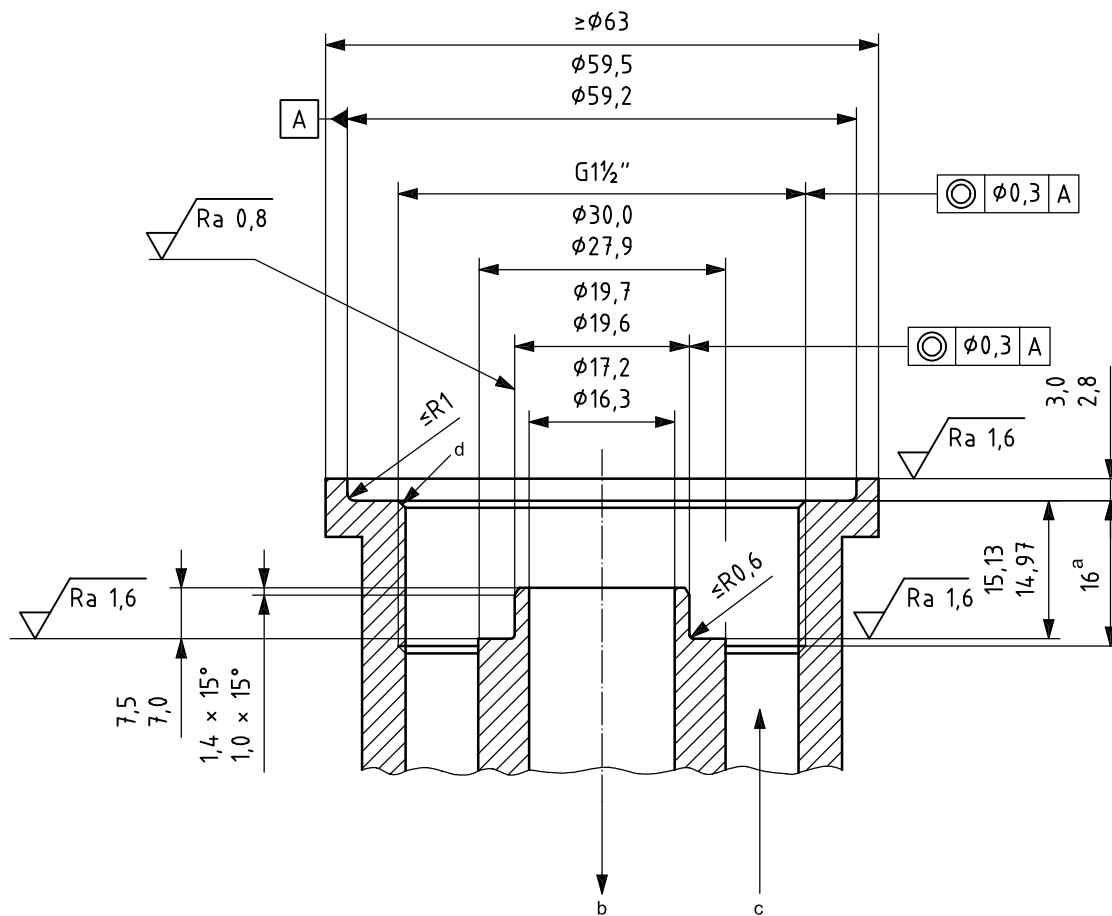

Key

- a Minimum, full thread.
- b Water flow out.
- c Water flow in.
- d Chamfer of 45°.

NOTE Machined surface roughness is 3,2 µm unless otherwise stated. Tolerance on angles is ± 3°.

Figure A.1 — Example manifold dimensions: G 1 1/2" concentric meters

Dimensions in millimetres
Surface roughness in micrometres

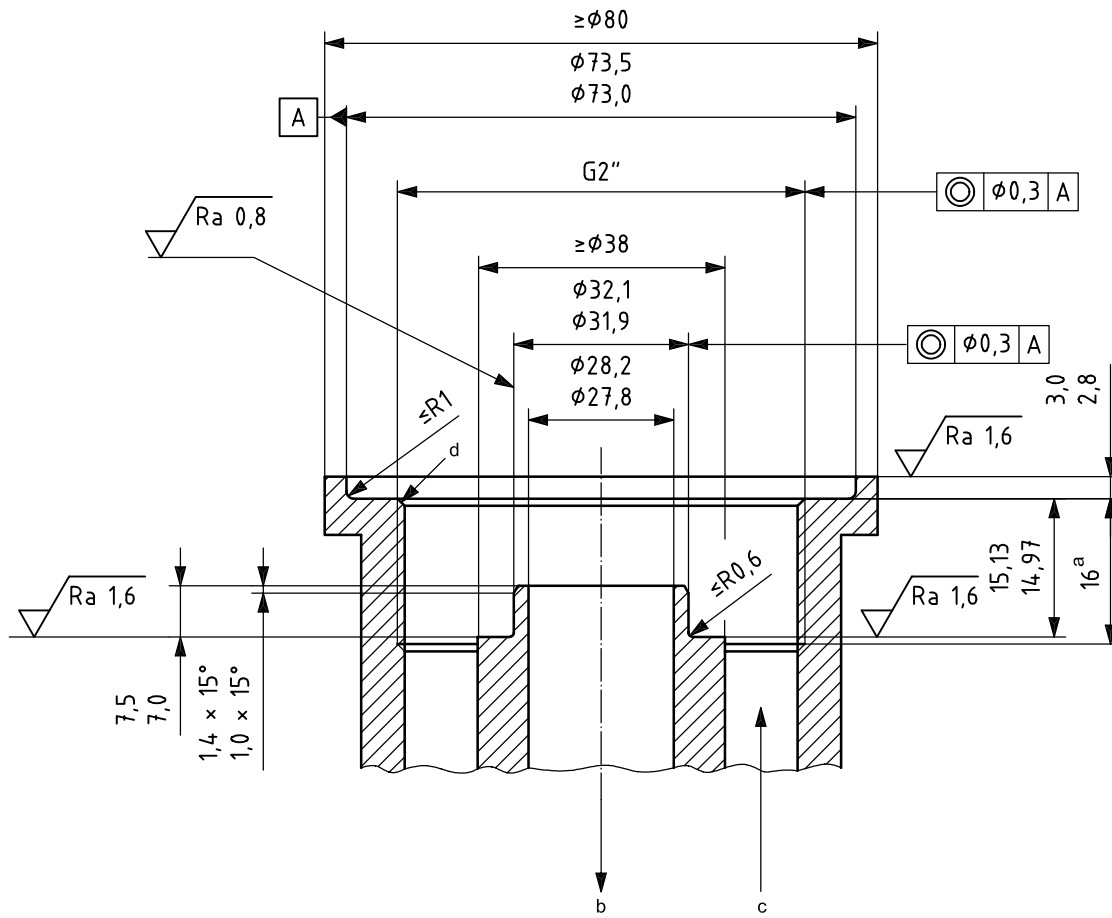

Key

- a Minimum, full thread.
- b Water flow out.
- c Water flow in.
- d Chamfer of 45°.

NOTE Machined surface roughness is 3,2 μm unless otherwise stated. Tolerance on angles is ± 1°.

Figure A.2 — Example manifold dimensions: G 2" concentric meters

Annex B (informative)

Design features and actual flowrates of water meters

B.1 Design features of water meters

Product design may enable a water meter to exceed the normative requirements of this part of ISO 4064, e.g. in actual flowrates achievable. As a demonstration of this, definitions of actual continuous, high, low and intermediate flowrates are given and illustrated in B.2. Factors that influence the design of water meters include materials of construction (for strength and durability, and to minimize contamination of the water flowing through the meter), water temperature and operating pressures, range of flowrate desired, pressure difference across the meter at maximum flowrate, and range of ambient temperatures and humidity under operating conditions. Other factors include the conduit size and end connections, and installation constraints such as size and manoeuvrability.

B.2 Actual flowrates of a meter

B.2.1 General

Figure B.1 shows a sample water meter error curve. For this, the definitions set out in B.2.2 to B.2.5 apply.

B.2.2 Continuous flowrate

Continuous flowrate, Q_c , may be defined as the highest flowrate at which the water meter can actually operate in a satisfactory manner, within MPE under normal conditions of use, i.e. under steady and intermittent flow conditions.

B.2.3 High flowrate

High flowrate, Q_h , may be defined as the highest flowrate at which the water meter can actually operate in a satisfactory manner, within MPE for a short period of time without deteriorating.

B.2.4 Low flowrate

Low flowrate, Q_L , may be defined as the lowest flowrate at which the water meter can actually give indications that satisfy requirements concerning MPE in the lower zone (see definition 3.12).

B.2.5 Intermediate flowrate

Intermediate flowrate, Q_i , may be defined as the highest flowrate in the lower zone at which the actual meter error goes from above the value of MPE of the upper zone (see definition 3.12) to below the value of MPE of the upper zone.

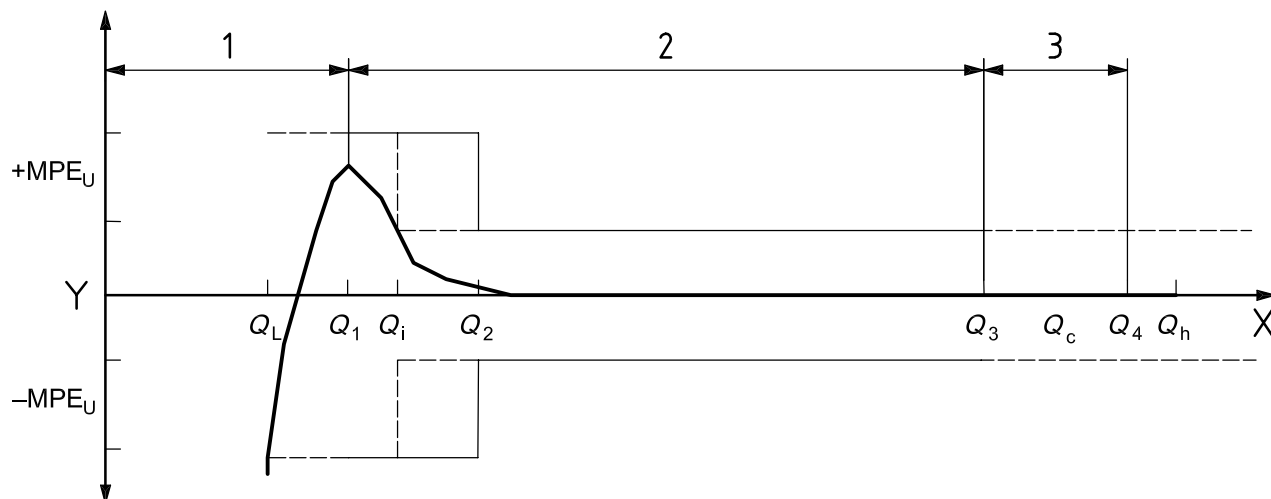

Key

X flowrate
 Y error of volume flow indication %

- 1 limiting conditions (LC)
- 2 rated operating conditions (ROC)
- 3 limiting conditions (LC)

NOTE Q_1 , Q_2 , Q_3 and Q_4 pertain to requirements for water meters as defined in Clause 5. Q_L , Q_i , Q_c and Q_h pertain to possible actual performance of a meter as defined in this annex.

Figure B.1 — Sample water meter error curve

Annex C (normative)

Checking facilities

C.1 Action of checking facilities

The detection by the checking facilities of significant faults shall result in the following actions, according to type.

For checking facilities of type P or I:

- automatic correction of the fault or
- stopping only the faulty device when the water meter without that device continues to comply with the regulations or
- a visible or audible alarm; this alarm shall continue until the cause of the alarm is suppressed. In addition, when the water meter transmits data to peripheral equipment, the transmission shall be accompanied by a message indicating the presence of a fault.

The instrument may also be provided with devices to estimate the volume of water having passed through the installation during the occurrence of the fault. The result of this estimate shall not be capable of being mistaken for a valid indication.

The visible or audible alarm is not allowed in the case of two constant partners, non-resettable and non-prepaid measurements, where checking facilities are used, unless this alarm is transferred to a remote station.

NOTE The transmission of the alarm and repeated measured values from the meter to the remote station need not be secured if the measured values are repeated at that station.

C.2 Checking facilities for the measurement transducer

C.2.1 The objective of these checking facilities is to verify the presence of the measurement transducer, its correct operation and the correctness of data transmission.

The verification of correct operation includes detection or prevention of reverse flow. However, it is not necessary for the detection or prevention of reverse flow to be operated electronically.

C.2.2 When the signals generated by the flow sensor are in the form of pulses, each pulse representing an elementary volume, the pulse generation, transmission and counting shall fulfil the following tasks:

- a) correct counting of pulses;
- b) detection of reverse flow, if necessary;
- c) checking of correct function.

This may be done by means of,

- three-pulse system with use of either pulse edges or pulse status;
- double-pulse line system with use of pulse edges plus pulse status;
- double-pulse system with positive and negative pulses depending on the flow direction.

These checking facilities shall be of type P.

It shall be possible during pattern approval to verify that these checking facilities function correctly:

- by disconnecting the transducer or
- by interrupting one of the sensor's pulse generators or
- by interrupting the electrical supply of the transducer.

C.2.3 For electromagnetic meters only, where the amplitude of the signals generated by the measurement transducer is proportional to the flowrate, the following procedure may be used.

A simulated signal with a shape similar to that of the measurement signal is fed into the input of the secondary device, representing a flowrate between the minimum and maximum flowrate of the meter. The checking facility shall check the primary and the secondary device. The equivalent digital value is checked to verify that it is within predetermined limits given by the manufacturer and consistent with the maximum permissible errors.

This checking facility shall be of type P or I. For type I facilities, checking shall occur at least every five minutes.

NOTE Following this procedure, additional checking facilities (more than two electrodes, double signal transmission etc.) are not required.

C.2.4 The maximum permissible cable length between primary and secondary devices of an electromagnetic meter, as defined in ISO 6817, shall be not more than 100 m or not more than the value L , expressed in metres, according to the following formula, whichever is smaller:

$$L = (k \times c)/(f \times C)$$

where

$$k = 2 \times 10^{-5} \text{ m};$$

c is the conductivity of the water, in siemens per metre;

f is the field frequency during the measuring cycle, in Hertz;

C is the effective cable capacitance, in farads per metre.

NOTE It is not necessary to fulfil these requirements, if the manufacturer's solutions ensure equivalent results.

C.2.5 For other technologies, checking facilities providing equivalent levels of security, remain to be developed.

C.3 Checking facilities for the calculator

C.3.1 The objective of these checking facilities is to verify that the calculator system functions correctly and to ensure the validity of the calculations made.

No special means are required for indicating that these checking facilities function correctly.

C.3.2 The checking facilities for the functioning of the calculation system shall be of type P or I. For type I the checking shall occur at least either once per day or for every volume equivalent to 10 min of flow at Q_3 .

The objective of this checking facility is to verify that:

- a) the values of all permanently memorized instructions and data are correct, by such means as:
 - 1) summing up all instruction and data codes and comparing the sum with a fixed value;
 - 2) line and column parity bits (longitudinal redundancy check and vertical redundancy check);
 - 3) cyclic redundancy check;
 - 4) double independent storage of data;
 - 5) storage of data in "safe coding", e.g. protected by checksum, line and column parity bits;
- b) all procedures of internal transfer and storage of data relevant to the measurement result are performed correctly, by such means as:
 - 1) write-read routine;
 - 2) conversion and re-conversion of codes;
 - 3) use of "safe coding" (check sum, parity bit);
 - 4) double storage.

C.3.3 The checking facilities for the validity of calculations shall be of type P or I. For type I the checking shall either occur at least once per day, or for every volume equivalent to 10 min of flow at Q_3 .

This consists of checking the correct value of all data related to the measurement whenever these data are internally stored or transmitted to peripheral equipment through an interface. This check may be carried out by such means as parity bit, check sum or double storage. In addition, the calculation system shall be provided with a means of controlling the continuity of the calculation programme.

C.4 Checking facility for the indicating device

C.4.1 The objective of this checking facility is to verify that the primary indications are displayed and that they correspond to the data provided by the calculator. In addition, it aims at verifying the presence of the indicating devices when they are removable. These checking facilities shall either have the form as defined in C.4.2 or the form as defined in C.4.3.

C.4.2 The checking facility of the indicating device is of type P; however, it may be of type I if a primary indication is provided by another device.

Means may include, e.g.:

- for indicating devices using incandescent filaments or light emitting diodes (LED), measuring the current in the filaments;
- for indicating devices using fluorescent tubes, measuring the grid voltage;
- for indicating devices using multiplexed liquid crystals (LCD), output checking of the control voltage of segment lines and of common electrodes, so as to detect any disconnection or short circuit between control circuits.

The checks mentioned in 6.7.3 are not necessary.

C.4.3 The checking facility for the indicating device shall include type P or type I checking of the electronic circuits used for the indicating device (except the driving circuits of the display itself); this checking facility shall meet the requirements of C.3.2.

C.4.4 It shall be possible during pattern approval to determine that the checking facility of the indicating device is working, either:

- by disconnecting all or part of the indicating device or
- by an action which simulates a failure in the display, such as using a test button.

C.5 Checking facilities for ancillary devices

An ancillary device (repeating device, printing device, memory device, etc.) with primary indications shall include a checking facility of type P or I. The aim of this checking facility is to verify the presence of the ancillary device, when it is a necessary device, and to verify correct functioning and correct transmission.

Bibliography

- [1] IEC 60068-2-2, am 2: 1994, *Environmental testing — Part 2: Tests. Tests B: Dry heat*
- [2] IEC 60068-3-1:1974, *Environmental testing — Part 3: Background information — Section One: Cold and dry heat tests*
- [3] IEC 60068-1:1988, am 1:1992, *Environmental testing. Part 1: General and guidance*
- [4] IEC 60068-2-1, am 2:1994, *Environmental testing — Part 2: Tests. Tests A: Cold*
- [5] IEC 60068-2-30:1980, am 1:1985, *Environmental testing — Part 2: Tests. Test Db and guidance: Damp heat, cyclic (12 + 12-hour cycle)*
- [6] IEC 60068-3-4:2001, *Environmental testing — Part 3-4: Supporting documentation and guidance — Damp heat tests*
- [7] IEC 61000-4-11:2004, *Electromagnetic compatibility (EMC) — Part 4-11: Testing and measurement techniques — Voltage dips, short interruptions and voltage variations immunity tests*
- [8] IEC 60068-2-64:(1993-05), *Environmental testing — Part 2: Test methods — Test Fh: Vibration, broad-band random (digital control) and guidance*
- [9] IEC 60068-2-47:(2005), *Environmental testing — Part 2-47: Test — Mounting of specimens for vibration, impact and similar dynamic tests*
- [10] IEC 60068-2-31:1969, *Environmental testing. Part 2: Tests. Test Ec: Drop and topple, primarily for equipment-type specimens*
- [11] IEC 61000-4-4:1995, *Electromagnetic compatibility (EMC) — Part 4-4: Testing and measurement techniques — Electrical fast transient/burst immunity test*
- [12] IEC 61000-4-2:1995 am 1:1998, *Electromagnetic compatibility (EMC) — Part 4: Testing and measurement techniques — Section 2: Electrostatic discharge immunity test. Basic EMC Publication*
- [13] IEC 61000-4-3:2002, *Electromagnetic compatibility (EMC) — Part 4-3: Testing and measurement techniques — Radiated, radio-frequency, electromagnetic field immunity test*
- [14] IEC 61000-4-5:2001, *Electromagnetic Compatibility (EMC) — Part 4-5: Testing and measurement techniques — Surge immunity tests*
- [15] BS 5728-7:1997, *Measurement of flow of cold potable water in closed conduits. Specification for single mechanical type*
- [16] OIML International Document Draft version R49 December 1997
- [17] OIML International Document D 4 *Installation and storage conditions for cold water meters*, 1981
- [18] *Guide to the expression of uncertainty in measurement (GUM)*, developed jointly by BIPM, IEC, IFCC, ISO, IUPAC, IUPAP and OIML, ISO, Geneva, 1995
- [19] ISO 6708:1980, *Pipe components — Definition of nominal size*
- [20] ISO 7268:1983, *Pipe components — Definition of nominal pressure*
- [21] ISO 7005-1:1992, *Metallic flanges — Part 1: Steel flanges*

- [22] WHO (Geneva), *Guideline for drinking water quality — Vol. 1: Recommendations* (1984)
- [23] EEC Council Directive of 15 July 1980 relating to drinking water for human consumption, Official Journal of the EEC, L229, pp. 11-29
- [24] ANSI/AWWA C700 AWWA Standard for cold-water meters-displacement type, bronze main case
- [25] ISO 4006:1991, *Measurement of fluid flow in closed conduits — Vocabulary and symbols*
- [26] ISO 13359, *Measurement of conductive liquid flow in closed conduits — Flanged electromagnetic flowmeters — Overall length*

.....

ICS 91.140.60

Price based on 42 pages